

Functions of the Multi-port Valve

- ⚠ Hazardous pressure. Can cause severe injury or major property damage from valve blow up. Release all pressure and read instructions before working on system**
- ⚠ To avoid severe injury and major property damage, stop pump before changing handle positions.**
- ⚠ To avoid major property damage due to flooding, make sure pointer is accurately positioned and down all the way before restarting pump.**

Press down on handle to release pressure before turning.

1. **FILTER** — Normal position during operation of system.
2. **BACKWASH** — Position when operating system to purge filter of accumulated debris. This normally is necessary when filter pressure gauge reads 10 PSI higher than starting pressure on a clean filter. Consult your filter operating instructions.
3. **RINSE** — This position is only used with sand filters and is designed to flush stray sand from system before returning to filter operation after backwashing. Consult your filter operation instructions.
4. **CLOSED** — Valve may be set in closed position when servicing filter tanks located below water level.
5. **RECIRCULATE** — This position permits pump to continue recirculating water (chemicals, heat, etc.) without flow through filter. This is advantageous when filter or its components are being repaired or replaced.
6. **WASTE** — This position permits draining or lowering of pool water level. When pump is stopped with valve in this position, quickly move handle to another position to avoid air getting into piping.

Valve Maintenance

- ⚠ To avoid severe personal injury and major property damage, stop pump and release all pressure from system before servicing valve.**

No regular maintenance is required for proper operation of multi-port valve.

Winterizing for Freezing Climates:

Place valve handle in an immediate position, between regular setting positions.

Part Replacement:

To prevent flooding, make sure that system is drained or isolation valves are closed before opening multi-port valve.

Replacing Handle:

1. STOP PUMP and release all pressure from system.
2. Place handle in "FILTER" position.
3. Remove all bolts and nuts holding cover to valve body.
4. Remove cover, handle, and plug as a unity from valve body.
5. Compress plug as shown in figures 1 and 2.
6. Remove handle pin from handle; remove handle and replace with new one, making sure pointer is in "FILTER" position (see fig.3).
7. Replace pin by tapping lightly into place with hammer and punch.
8. Remove fixture, align cover pin (see fig.3), and reinstall cover and plug. Tighten all bolts securely.

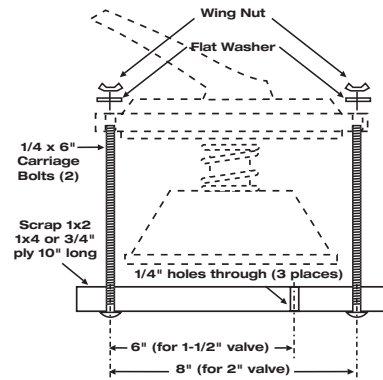

Fig. 1 - Fixture dimensions for valve spring compressor

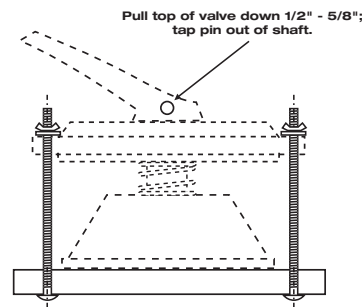

Fig. 2 - Tighten wingnuts to compress spring

To prevent flooding, make sure that the system is drained or isolation valves are closed before opening multi-port valve.

Replacing Cover and Plug Assembly (as a unit):

1. STOP PUMP and release all pressure from system.
2. Remove all bolts and nuts around perimeter of cover.
3. Remove assembly by lifting straight up.
4. Align cover pin (see fig. 3) and install new cover and plug. Press down on cover to allow bolts to engage nuts; tighten each bolt securely.

Replacing Internal Valve Parts:

1. STOP PUMP and release all pressure from system.
2. Place handle in "FILTER" position.
3. Remove all bolts and nuts.
4. Remove cover by lifting straight up.
5. Remove handle pin and handle (See procedure on prior page).
6. Remove washer.
7. While disassembled, check condition of plug, rubber gasket, spring, o-ring, and internal plastic washer, if any of these parts appear worn, replace them.
8. Reassemble plug, cover, and handle by compressing spring (see figs. 1 & 2) and reversing procedure on previous page.
9. Before reinstalling cover, be sure plug and handle are in same position as when cover was removed.
10. Make tab on valve cover align with pin on top of pump port (see fig. 3). Press down on cover or set handle to "WINTERIZE" to allow bolts to engage nuts. Tighten each bolt securely.

Spider Gasket Replacement:

NOTICE: Read instructions completely before starting. Once step 6 is started, continue through step 10 without interruption.

1. STOP PUMP and release all pressure from system.
2. Place the selector handle at the "WINTERIZE" position (this lifts the plug off the seat).
3. Remove the bolts and nuts holding the cover to the valve body. Remove the cover assembly.
4. Remove the old gasket from the valve body.
5. Make sure that the gasket groove is free of water, grease, oils, debris and parts of the old gasket. Use alcohol to degrease.
6. **NOTICE:** Once this step is started, continue through step 10 without interruption. Using Loctite® 401 or 416, apply glue sparingly (a bead about 1/16" wide) to the bottom only (not the sides) of the spider groove in the valve body. The glue lines must be continuous and intersect at the intersections of the grooves.
7. Insert the gasket into the groove with the rounded bead up. Press the gasket firmly into all groove areas to seat the new gasket evenly.
8. Align the tab on the cover assembly with the pin on the valve body (see fig. 3) and insert the cover assembly into the body, fastening with the bolts and nuts removed in step 3. Tighten all bolts securely.
9. Depress the valve handle and rotate it to the closest standard position (FILTER or RINSE), being careful not to rub the plug on the new gasket. Release the handle, allowing the plug to hold the gasket in place while curing.
10. Minimum cure time is 2 hours. Curing for 24 hours is recommended for full strength.

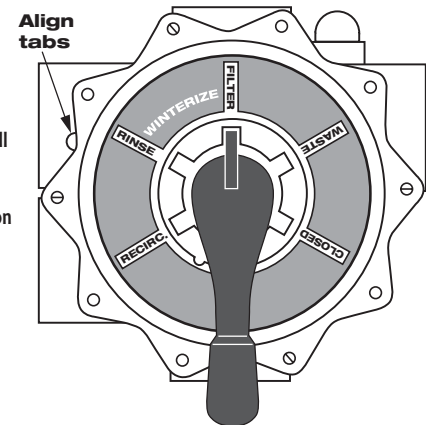
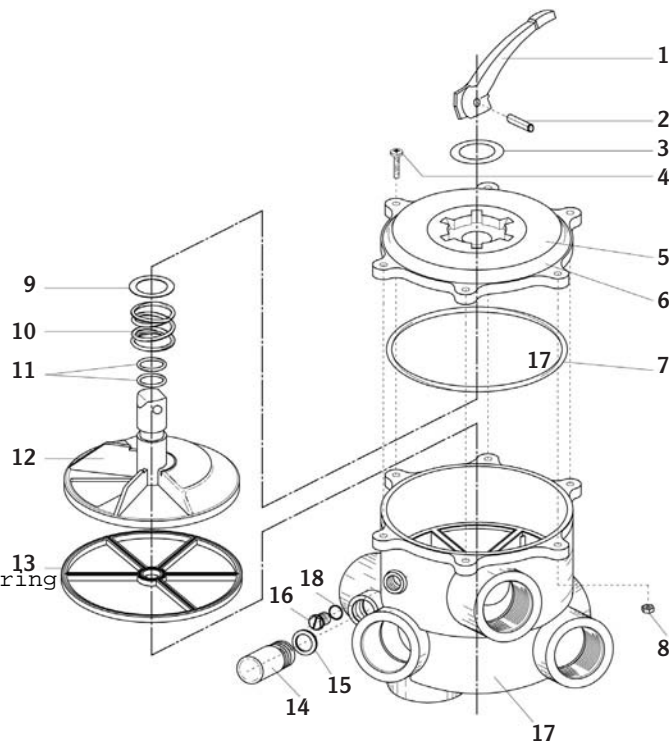

Fig. 3 - Cover alignment (2" Valve)

Multi-Port Valve Assembly

- 1 Handle
- 2 Handle pin
- 3 Washer
- 4 Bolt
- 5 Label
- 6 Cover
- 7 Cover O-ring
- 8 Nut
- 9 Washer
- 10 Spring
- 11 O-rings
- 12 Diverter
- 13 Star gasket
- 14 Sight Glass
- 15 Gasket
- 16 Plug
- 17 Housing
- 18 O-ring
- 19 Plate
- 20 Diffuser

Side Mount Multi-Port Valve



Top Mount Multi-Port Valve

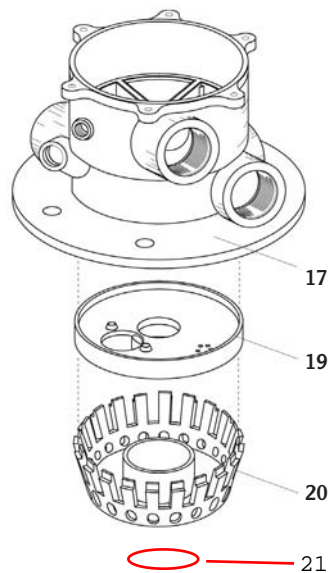

Multi-Port Valves

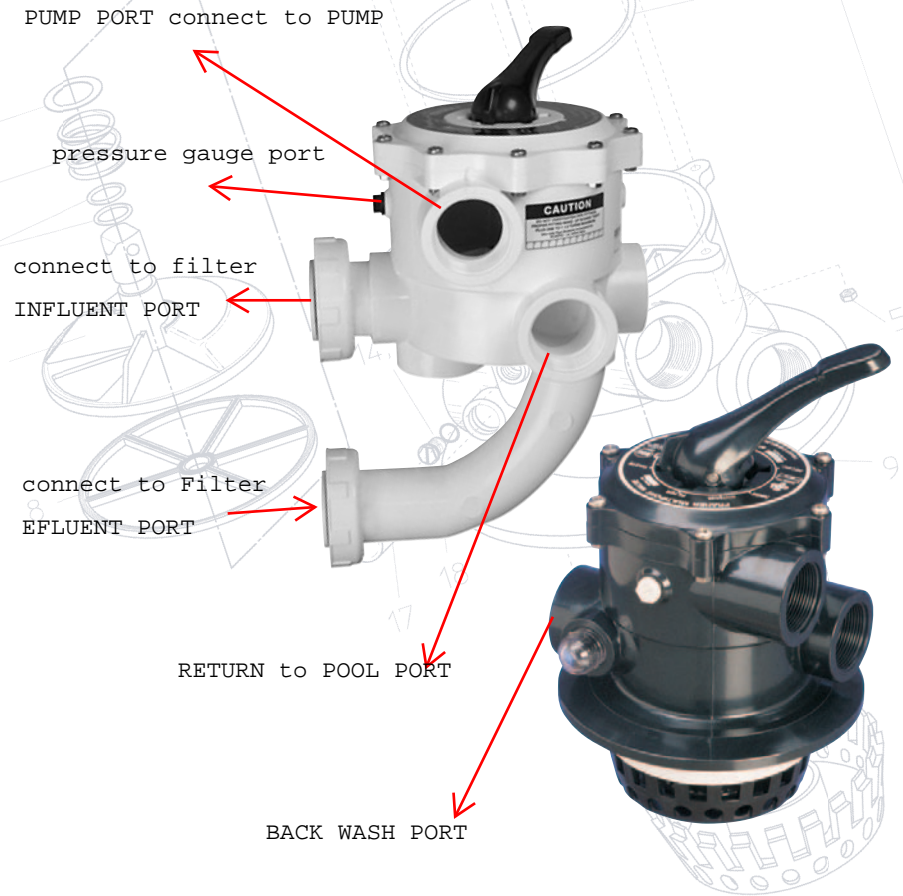

Praher Canada Ltd., 101 Saunders Road, Barrie, ON L4N 6E7 Tel: (705) 725-1100 Fax: (705) 725-0444

Side Mount Multiport Valve
Top Mount Multiport Valve